



MODEL KTM DUKE 390

YEAR 2013-2016

LINE FULL SYSTEM

MUFFLER GP

SCHEMATIC

ELENCO PARTI / PARTS LIST

#	QTÀ / QTY	DESCRIZIONE / DESCRIPTION	CODICE / CODE
1	1	DB killer / DB killer	50.DK.020.0
2	1	Silenziatore / Muffler	GP
3	1	Protezione in gomma / Rubber protection	50.73.077.1
4	1	Staffa / Bracket	50.SS.241.1
5	2	Dado M6 autobloccante / M6 locknut	50.73.112.1
6	4	Rondella M6 / Washer M6	50.72.027.1
7	2	Vite M6 x 12 / Screw M6 x 12	50.72.024.1
8	1	Vite M8x70 / Screw M8x70	50.73.086.1
9	1	Rondella in alluminio / Aluminium washer	50.73.063.1
10	1	Distanziale in alluminio / Aluminium spacer	50.SS.150.1
11	1	Staffa / Bracket	50.SS.687.0
12	3	Dado M8 flangiato / Flanged nut M8	50.73.393.1
13	1	Tubo di raccordo / Link pipe	9773KT009S7B
14	1	Silenziatore / Muffler	9873KT009S2A
15	1	Tubo di raccordo / Link pipe	9773KT012S7A
16	1	Distanziale alluminio / Aluminium spacer	50.SS.058.1
17	1	Rondella in alluminio / Aluminium washer	50.73.248.1
18	1	Vite M8x40 / Screw M8x40	50.73.075.1
19	1	Vite M8x16 / Screw M8x16	50.73.006.1
20	1	Guarnizione in grafite / Graphite bush	50.72.42.49.29
21	1	Fascetta Ø 48/51 mm / Pipe clamp Ø 48/51 mm	50.FA.007.1
22	1	Molla lunga / Long spring	50.71.080.1
23	1	Tubo per molla / Rubber pipe for spring	50.73.210.1

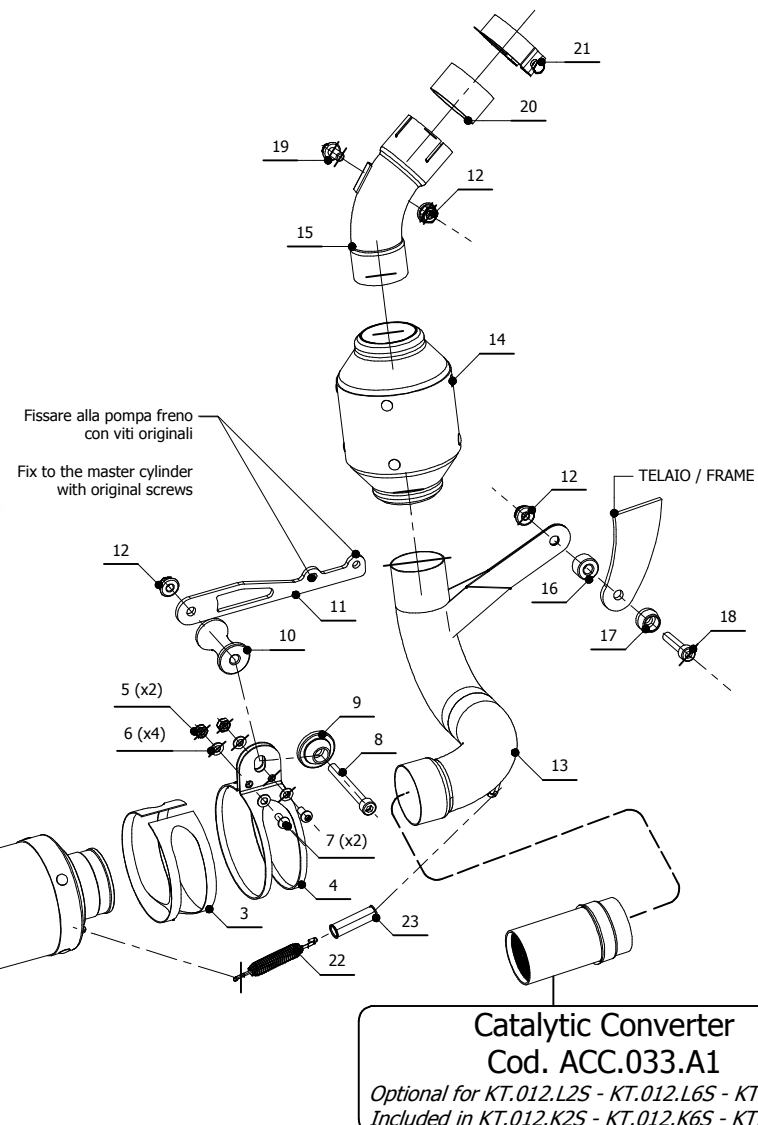
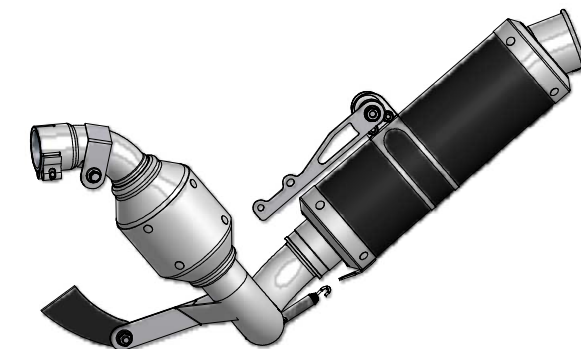
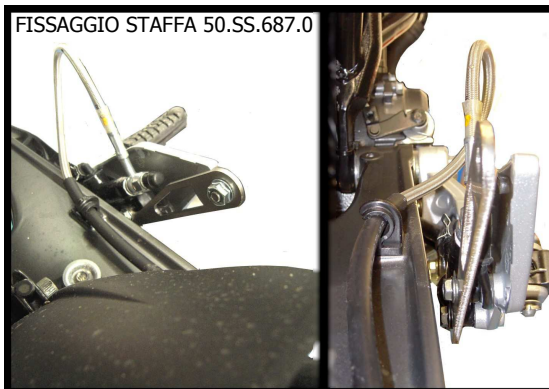

APPLICAZIONI / APPLICATIONS

CODICE / CODE	TUBO / PIPE	SILENZIATORE / MUFFLER	FASCETTA / CLAMP	NOTE
KT.012.L2S KT.012.L6S KT.012.LXB	INOX / ST. STEEL	CARBONIO / CARBON FIBERTITANIO / TITANIUM STEEL BLACK	INOX / ST. STEEL	CATALYTIC CONVERTER NOT INCLUDED
KT.012.K2S KT.012.K6S KT.012.KXB	INOX / ST. STEEL	CARBONIO / CARBON FIBERTITANIO / TITANIUM STEEL BLACK	INOX / ST. STEEL	CATALYTIC CONVERTER INCLUDED